

The strongest architectural
profile in the market.

SNAP-LINE 45[®] PANEL SYSTEM



Snap-Line45[®]

Distinctive style, rugged durability.



Snap-Line45®

With a 45mm deep, thin rib Snap-Line 45® has standard cover widths of 305mm, 345mm and 445mm. To offer even more flexibility, these can be varied from 200mm to 600mm.

Choose from various materials such as Colorbond®, Zinalume®, Zinc, Copper, Aluminium, Stainless Steel, Corten and the Uni-Cote® Lux Range. This gives the designer and architect many options when looking to achieve the desired aesthetics for their roofing and walling project.

Extensively tested and certified by an independent engineer in accordance to AS1562.1-2018, Snap-Line 45® is a structural, self supporting profile that does not require continuous backing*. It is the strongest architectural profile in the market. Performance Test Data available upon request.

*Softer metals such as Zinc and Copper will require continuous substrate backing under the sheet.



Durability

- ✓ Thermal Performance
- ✓ Extensive Range of Colours & Materials
- ✓ Moss & Lichen Resistant
- ✓ Frost Resistant
- ✓ Fire Resistant
- ✓ Waterproof
- ✓ Wind Resistant



Features

- ✓ Can be used for roof and wall applications
- ✓ Suitable for vertical and horizontal wall installation
- ✓ Certified to 1 degree roof pitch
- ✓ Compliance to Australian Standards and tested for wind load, waterproofing and combustibility
- ✓ Tested & Certified to AS 1562.1:2018
- ✓ The strongest Architectural Profile on the market
- ✓ Tested & Certified for Cyclonic Regions



Material Options

Snap-Line 45® can be manufactured in a wide range of material options including: painted/coated steel, aluminium, titanium zinc, stainless steel, and copper.

For material selection and information about possible incompatibility with other building materials (ie. metal galvanic dissimilarity), please consult with No1 APS team.





Snap-Line45®

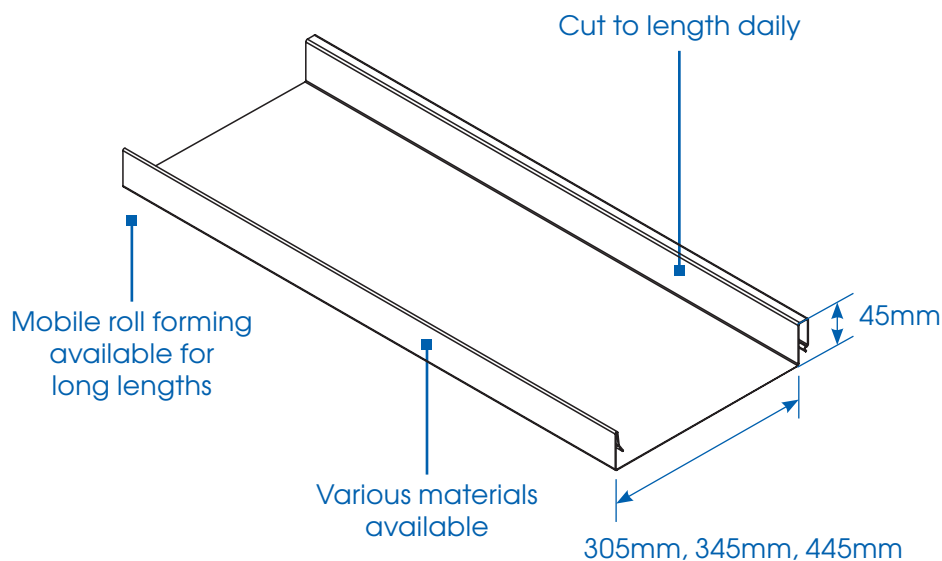

Clip relief and longitudinal striations on panels available upon request.

Technical Specifications

Rib Height	45mm
Standard Pan widths	305mm, 345mm, 445mm
Minimum sheet length	300mm
Custom Pan Widths	Range 200mm to 600mm (May require additional design parameters)

Tested and certified to comply with AS 1562.1:2018
Design and Installation of Sheet Roof and Wall Cladding - Metal.
It replaces AS 1562.1-1992

Cyclone tested and certified

Concealed fixed

Roll on Site option available - great for long sheets

For additional design parameters or project specific technical data,
please contact the No1 Architectural Panel Systems team.



Distributed by
No1 Roofing and Building Supplies
1300 742 011
aps@no1roofing.com.au
www.no1aps.com.au



No1 Roofing & Building Supplies



No1 Architectural Panel Systems
Manufactured by No1 Roofing & Building Supplies

1300 742 011
aps@no1roofing.com.au

www.no1aps.com.au

Version Two