

LONGLINE 305[®]

DESIGN AND INSTALLATION GUIDE

LYSAGHT



LYSAGHT LONGLINE 305®

STEEL ROOF CLADDING WITH LONG, CLEAN LINES

LONGLINE 305® is a concealed fixed roof cladding with bold ribs and wide pans. It is ideal for medium to large commercial projects where special architectural effects are desired. It has also been popular in industrial and residential applications.

The unique locking system fixes the cladding to the clip so no fasteners pass through the roofing. Concealed fixing means there are no penetrations so weathertightness is maximised and a high rainfall capacity is achieved.

LONGLINE 305®'s unique ability (among LYSAGHT® claddings) to be fluted or tapered. The taper allows fanned and rounded plan roof shapes to be clad with ribs radiating from a central point. Stylish indeed!

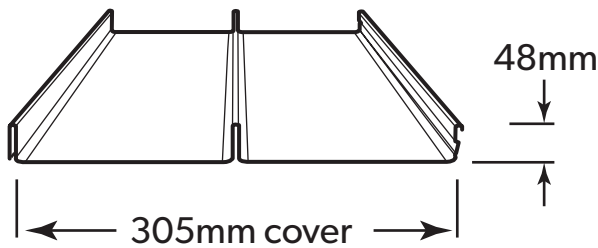

MATERIAL SPECIFICATIONS

Magnesium alloy coated steel complies with AS 1397:2011 G300, AM125 (300 MPa minimum yield stress, 125 g/m² minimum coating mass).

COLORBOND® is pre-painted steel for exterior roofing and walling. It is the most widely used. The painting complies with AS/NZS 2728:2013 and the steel base is an aluminium/zinc alloy-coated steel complying with AS 1397:2011. Minimum yield strengths are G300 (300 MPa). Minimum coating mass is AM100 (100 g/m²).

COLORBOND® Metallic is pre-painted steel for superior aesthetic qualities displaying a metallic sheen.

COLORBOND® Ultra is pre-painted steel for severe coastal or industrial environments (generally within about 100-200 metres of the source). The painting complies with AS/NZS 2728:2013 and the steel base is an aluminium/zinc alloy-coated steel complying with AS 1397:2011. Minimum coating mass is AM150 (150 g/m²).

COLORBOND® Stainless is a pre-painted steel and is used for severe and coastal environments. The painting complies with AS/NZS 2728:2013 and the steel base is a stainless steel complying with AISI/ASTM Type 430; UNS No. S43000.

Not available in metallic finishes as a standard item. Subject to enquiry.

The base metal thickness is 0.70mm.

The COLORBOND® pre-painted steel complies with AS/NZS 2728:2013.

COLOURS

LONGLINE 305® is available in an attractive range of colours in COLORBOND® factory pre-painted steel and in unpainted ZINCALUME® steel.

COLORBOND® STEEL WITH THERMATECH® TECHNOLOGY

THERMATECH® solar reflectance technology is now included in the standard COLORBOND® steel palette. COLORBOND® steel with THERMATECH® technology reflects more of the sun's heat, allowing both roofs and buildings stay cooler in summer. In moderate to hot climates, compared to roofing materials of similar colour with low solar reflectance, COLORBOND® steel with THERMATECH® can reduce annual cooling and energy consumption by up to 20%.

LENGTHS

Sheets are supplied custom cut.

MASSES

	BMT	kg/m	kg/m ² *	m ² /t*
Plain ZINCALUME®	0.70	2.96	9.70	103
Plain COLORBOND®	0.70	2.99	9.81	102
Fluted ZINCALUME®	0.70	2.96	9.86	101
Fluted COLORBOND®	0.70	2.99	9.96	100

* For tapered LONGLINE 305®, contact your local Service Centre. Fluted LONGLINE 305® is 300mm cover.

TOLERANCES

Length: + 0mm, - 15mm, Standard & fluted width: + 4mm, - 4mm, Tapered width: + 5mm, - 5mm

MAXIMUM SUPPORT SPACINGS

The maximum recommended support spacings are based on testing in accordance with AS 1562.1:1992, AS 4040.1:1992 and AS 4040.2:1992. Supports must not be less than 1mm BMT. Roof spans consider both resistance to wind pressure and light roof traffic (traffic arising from incidental maintenance). Wall spans consider resistance to wind pressure only. The figures relate only to buildings 10m or less in height. The figures given relate to Region B, Terrain Category 3, $M_s=0.85$, $M_i=1.0$, $M_t=1.0$ with the following assumptions made:

ROOFS:

$C_{pi}=+0.20$, $C_{pe}=-0.90$, $K_f=2.0$ for single and end spans, $K_f=1.5$ for internal spans.

WALLS:

$C_{pi}=0.20$, $C_{pe}=-0.65$, $K_f=2.0$ for single and end spans, $K_f=1.5$ for internal spans.

MAXIMUM SUPPORT SPACINGS (MM)

Type of Span	BMT 0.70 mm
Roofs	
Single span	1800
End span	2000
Internal span	2500
Unstiffened eaves overhang	150
Stiffened eaves overhang	450
Walls	
End span	2700
Internal span	2700
Overhang	450

For roofs: the data are based on foot-traffic

For walls: the data are based on pressures (see wind pressure table)

Supports must be not less than 1mm BMT

LONGLINE 305®: LIMIT STATE WIND PRESSURE CAPACITIES (KPA) 0.70MM BMT

Span Type	Limit State	Span (mm)						
		900	1200	1500	1800	2100	2400	2700
Single	Serviceability	2.60	2.10	1.70	1.35	1.10	0.95	0.80
	Strength*	3.60	3.25	2.85	2.70	2.40	2.20	1.95
End	Serviceability	1.45	1.45	1.40	1.35	1.30	1.25	1.15
	Strength*	4.20	3.80	3.45	3.15	2.75	2.45	2.25
Internal	Serviceability	2.05	1.90	1.80	1.65	1.55	1.45	1.30
	Strength*	5.20	4.90	4.55	4.15	3.65	3.05	2.50

*Support must be ≥1mm BMT. Capacity is based on tests with no insulation under the sheeting.

SPAN TYPES

Roofing & Walling Profiles

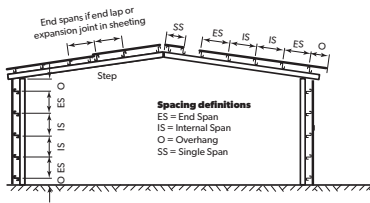

LIMIT STATES WIND PRESSURES

The wind pressure capacities are based on tests conducted at Lysaght’s NATA registered testing laboratory. Testing was conducted in accordance with AS 1562.1:1992 Design and Installation of Sheet Roof and Wall Cladding—Metal, and AS 4040.2:1992 Resistance to Wind Pressure for Non-cyclonic Regions.

The pressure capacities for serviceability are based on a deflection limit of $(\text{span}/120) + (\text{maximum fastener pitch}/30)$.

The pressure capacities for strength have been determined by testing the cladding to failure (ultimate capacity).

These pressures are applicable when the cladding is fixed to a minimum of 1.0mm, G550 steel.

For material less than 1.0mm thick, seek technical advice from Steel Direct on 1800 641 417.

ADVERSE CONDITIONS

If this product is to be used in marine, severe industrial, or unusually corrosive environments, ask for technical advice from Steel Direct.

MAXIMUM ROOF LENGTHS FOR DRAINAGE MEASURED FROM RIDGE TO GUTTER (M)

Penetration will alter the flow of water on a roof. For assistance in design of roofs with penetrations, please seek advice from our information line.

Peak Rainfall Intensity mm/hr	Roof Slopes (degrees)					
	1	2	3	5	7.5	10
100	219	273	320	398	475	546
150	146	182	213	265	317	364
200	110	136	160	199	237	273
250	88	109	128	159	190	218
300	73	91	107	133	158	182
400	55	68	80	100	119	136
500	44	55	64	80	95	109

NON-CYCLONIC AREAS

The information in this brochure is suitable for use only in areas where a tropical cyclone is unlikely to occur as defined in AS 1170.2:2002.

For information on the use of LYSAGHT® products in cyclonic conditions, refer to the Cyclonic Area Design Manual which is available on our website: www.lysaght.com or by ringing Steel Direct on 1800 641 417.

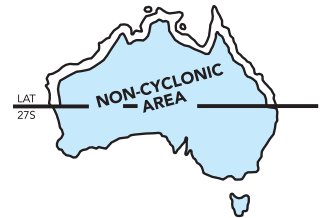

INSTALLATION

Method 1

Method 1 installation is typical practice used on of large commercial roofs.

PREPARATION

Before starting, check that the supports on which your sheeting will rest are in the same plane; that the pitch and overhangs conform to the minimum specifications.

ORIENT SHEETS BEFORE LIFTING

Consider which end of the building is best to start from. So that side laps are protected, we recommend that you start laying sheets from the end of the building that will be in the lee of the worst anticipated or prevailing weather.

It is much easier and safer to turn sheets on the ground than up on the roof. Before lifting sheets on to the roof, check that they are the correct way up and the overlapping side is towards the edge of the roof from which installation will start.

Place bundles of sheets over or near firm supports, not at mid span of roof members.

PREPARE CLIPS

Cut all starting/finishing clips and discard the unwanted pieces (Figure 1).

FIX THE FIRST ROW OF CLIPS

With particular care, determine the location of the first sheet and mark the edge of the sheet on the purlins.

Fix the first starting clip on the purlin. Using a string line (or the first sheet as a straight edge) fix the other starting clips for the first sheet on each purlin.

PLACE THE FIRST SHEET

1. Locate the first sheet over the fixed starting clips (Figure 2).
2. Using a measurement from the gutter-end of the sheet to the fascia or purlin, position the sheet so that it overhangs the desired amount into the gutter.

When setting the first sheet, remember that it is important you keep the gutter-end of all sheets at a constant distance from the edge of the gutter or fascia.

3. Bend the tab of all clips over the rib (Figure 3).

FIX THE NEXT (AND SUBSEQUENT) CLIPS AND SHEETS

1. Using the rib closing tool, squash the male rib of the first (previous) sheet at each purlin where the top fixing clips will fit (Figure 4).
2. Place top fixing clips over each squashed male rib and fix to the purlins (Figure 5). With a felt-tipped pen, make a small mark in the pan to enable you to locate the clips in the later locking operation with the button punch (Figure 6).
3. Place the next sheet over the edge of the preceding sheet (Figure 5). Accurately position the sheet so that it overhangs the desired amount into the gutter.
4. Fully engage the sheet with the clips, using foot pressure on the ribs over each clip. You can do this by walking along the full length of the sheet with one foot in the tray next to the overlapping rib and the other foot applying pressure to the top of the interlocking ribs at regular intervals.

CHECK ALIGNMENT PERIODICALLY

Check that sheets are still parallel with the first sheet.

PLACE THE LAST SHEET

Assess how the last sheet will fit in relation to the fascia.

Fix a cut starting/finishing clip to the purlins.

Place the last sheet over the finishing clips, and bend the tab of all clips over the rib. (Similar to the steps used in the first sheet, Figures 2 & 3).

LOCK ALL RIBS

All lapped ribs must be locked along their length, by button-punching at the clips, and if necessary between the clips (typically at 900mm centre to centre.) (Figure 6). Punching to a string line guide stretched across the sheeting is recommended as random punching mars the appearance of the finished work.

You must button-punch through the hole in each top fixing clip – you locate the clip with the pen mark made previously. When operating the punching tool, stand on the pan of the overlapping sheet to ensure that the sheets are fully engaged.

For advice on button-punching either side of the clip, contact your nearest Service Centre.

ENDS OF SHEETS

Wind can drive water uphill under the flashings or cappings. Also, at the low end of a roof, wind or capillary action can cause water to run back up the underside of sheeting. To minimise these problems, turn the pans up at the top of sheets, and turn them down at the bottom. A tool is available for these jobs (Figure 7).

TURNING-UP

Flush turn-ups are usually used on LONGLINE 305®. Cut off a portion of the female rib for at least 50mm. For a flush turn-up, you also need to cut the crown of the centre rib for at least 50mm.

Holding the end of the tool against the end of the sheet, pull the handle up 90°. If turning-up flush, fold the protruding ears flush against the turn-up tool with a rubber mallet (Figure 8).

TURNING-DOWN

All roofing on slopes below 1 in 5 (10°) must be turned-down (also called lipped).

Turning-down is usually done after the sheeting is fixed on the roof, provided there is no obstruction to the operation of the turn-down tool.

- Push the turn-down tool over the end of the tray, as far as it will go.
- Hold the tool hard against the end of the tray and push the handle to form a turn-down of about 20° (Figure 9).

Method 2

The following installation is an alternative approach used on some commercial and residential roofs where SHEERLINE® gutter is to be fitted as a longitudinal barge fascia.

PREPARE CLIPS

Cut all start/finishing clips and discard the unwanted piece (Figure 10).

INSTALLATION

Consider which end of the building is best to start from.

1. Position the starting/finishing clips on each support by placing onto the support nearest the gutter fascia.
2. The turned down tab under the starting/finishing clip is used to position the overhang of the clips. On timber purlins an

additional screw or nail is driven through the hole in the tab into the purlins (Figure 11).

3. Position the first sheet by locating the female rib under the tab on the upstand of the starting/finishing clips after locating the sheet longitudinally for gutter overhang etc. Then secure the sheet by folding the pre-bent clip upstands down over the female rib (Figure 11).
If the tray turn-up at the high end of the sheeting is to be flush-stop ended, this should be done before positioning the sheets and allow an extra 50mm on the sheet length.
4. Similarly for the stat/finish clips at the end of the roof area, and install the last sheet in a similar fashion (Figure 12).

Figure 1

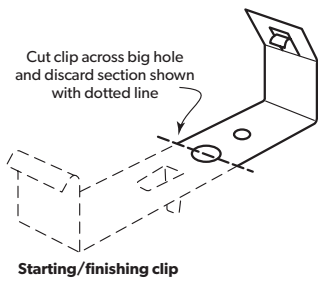

Figure 2

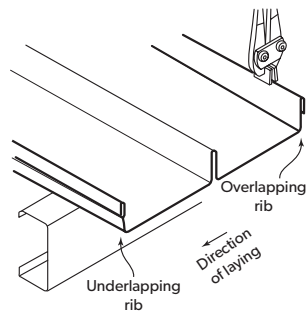

Figure 3

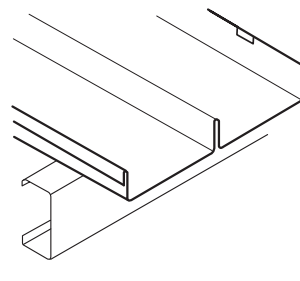

Figure 4

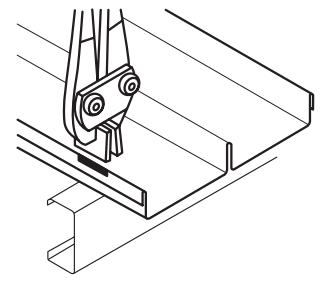

Figure 5

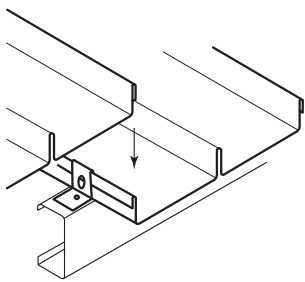

Figure 6

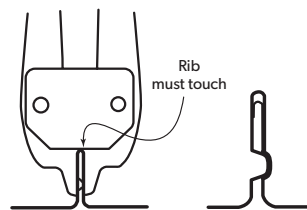

Figure 7

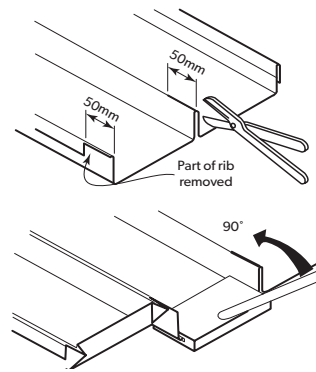

Figure 8

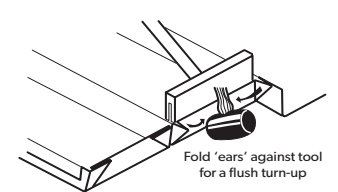

Figure 9

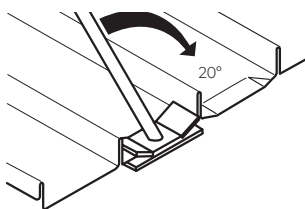

Figure 10

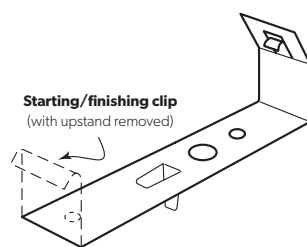

Figure 11

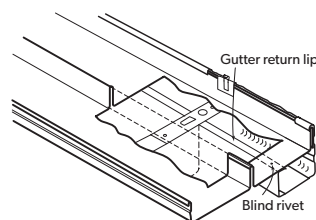
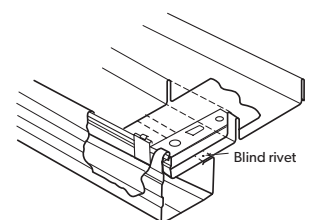

Figure 12



Starting/finishing clip used as shown at start of roof when SHEERLINE® gutter required as fascia (use a blind rivets or wafer head screws to fasten the return leg of the SHEERLINE® gutter).

Starting/finishing clip used as shown at finish of roof when SHEERLINE® gutter required as fascia.

INSTALLATION

FASTENING SHEETS TO SUPPORTS

LONGLINE 305® is concealed-fixed to supports. This means that clips are screwed to the supports, and no fastening passes through the sheeting.

There are two types of fixing clips - a top finishing clip and a start/finishing clip to fasten the first and last sheets in a roof area.

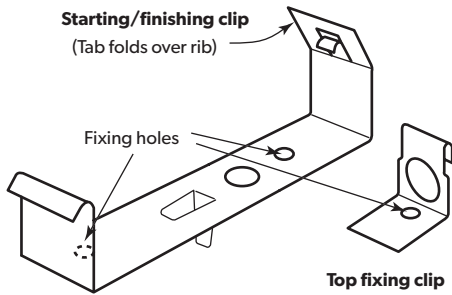

END-LAPPING

LONGLINE 305® is available in very long lengths and thus end-lapping of sheets is not commonly needed. However if sheets need to be end-lapped then the under-sheet ribs have to be slightly squashed at the lap, and for the length of the lap, to allow the over-sheet to nest snugly. The rib closing tool may be suitable to squash the ribs.

Note:

As an alternative, to the starting/finishing clip, the top fixing clip is often used in this situation. The female rib of the first sheet will need to be squashed in a similar manner to the male rib to allow the top fixing clip to be installed. The rib can be squashed using the rib closing tool.

WALKING ON ROOFS

Generally, keep your weight evenly distributed over the soles of your feet to avoid concentrating your weight on either heels or toes. Always wear smooth soft-soled shoes; avoid ribbed soles that pick up and hold small stones, swarf and other objects.

Whatever direction you walk, always walk in the pans. When walking across the width of the roof, walk over, or close to, the roof supports.

SHEET COVERAGE

Width of Roof (m)	3	4	5	6	7	8	9	10	11	12	13	14	15	16	17	18	19	20	30	40	50
Number of Sheets	10	14	17	20	23	27	30	33	37	40	43	46	50	53	56	60	63	66	99	132	164

FASTENERS WITHOUT INSULATION

	Fix to Steel (Total 2.0mm) Single & lapped steel thickness ≥0.55 up to 1.0mm BMT	Fix to Steel Single steel thickness >1.0mm BMT up to 3.0mm BMT	Fix to Steel (Total 3.8mm) Lapped thicknesses of >1.00 BMT up to 1.9mm BMT	Fix to Timber Hardwood J1-J3	Fix to Timber Softwood J4
Clip Fixed	10-16x16, Metal Tek's, WH or 10-16x22, Metal Tek's, WH	10-16x16, Metal Tek's, WH or 10-16x22, Metal Tek's, WH	10-16x16, Metal Tek's, WH or 10-16x22, Metal Tek's, WH	10-12x25, Type 17, WH	10-12x35, Type 17, WH

Notes:

1. For other steel thicknesses not specified please seek advice from screw manufacturer
2. WH = Wafer Head
3. Use one screw per clip
4. As above or equivalent fastener

MAINTENANCE

Optimum product life will be achieved if all external walls are washed regularly.

Areas not cleaned by natural rainfall (such as the tops of walls sheltered by eaves) should be washed down every six months.

SAFETY, STORAGE AND HANDLING

LYSAGHT® product may be sharp and heavy.

It is recommended that heavy-duty cut resistant gloves and appropriate manual handling techniques or a lifting plan be used when handling material.

Keep the product dry and clear of the ground. If stacked or bundled product becomes wet, separate it and wipe it with a clean cloth to dry thoroughly.

Handle materials carefully to avoid damage: don't drag materials over rough surfaces or each other; don't drag tools over material; protect from swarf.

METAL & TIMBER COMPATIBILITY

Lead, copper, free carbon, bare steel and green or some chemically-treated timber are not compatible with this product. Don't allow any contact of the product with those materials, nor discharge of rainwater from them onto the product. Supporting members should be coated to avoid problems with underside condensation. If there are doubts about the compatibility of other products being used, ask for advice from our information line.

CUTTING

For cutting thin metal on site, we recommend a circular saw with a metal-cutting blade because it produces fewer damaging hot metal particles and leaves less resultant burr. Do not use a carborundum disc.

Cut materials over the ground and not over other materials.

Sweep all metallic swarf and other debris from roof areas and gutters at the end of each day and at the completion of the installation. Failure to do so can lead to surface staining when the metal particles rust.

SEALED JOINTS

For sealed joints use screws or 4.8mm sealed blind rivets and neutral-cure silicone sealant branded as suitable for use with galvanised or ZINCALUME® steel.

VERSATILE VARIATIONS OF LONGLINE 305® PRODUCTS

For assistance with LONGLINE 305® fluted and LONGLINE 305® tapered, please contact your nearest Service Centre.

The LONGLINE 305® products are a bold ribbed cladding profile for application where an aesthetic smart and clean lined cladding is required in commercial, industrial and residential projects.

With combinations of fluted and tapered sheets, and/or with spring curving, striking or special architectural effects can be achieved.

The tapered LONGLINE 305® results in a fan effect on roofs. Alternating the arrangement of tapered sheets or the combination of tapers/fluted or standard LONGLINE 305® sheets will result in various patterns and textures being achieved.

LONGLINE 305® PRODUCTS

The LONGLINE 305® cladding product is available in cover widths of:

- LONGLINE 305® - Traditional wide flat pans, with a uniform cover width of 305mm.
- Fluted LONGLINE 305® - Flat panned profile with subtle "concertina" type stiffeners running longitudinally in the pans with a uniform cover width of 300mm (other fluted dimensions may be available subject to enquiry).
- Tapered LONGLINE 305® - "Concertina" type stiffeners running longitudinally in the pans varying from a subtle definition to a bold definition. Cover width varying from a wide end of 305mm, down to a narrow end of as low as 145mm.

Notes:

1. Fluted LONGLINE 305® of cover width less than 300mm may be available subject to enquiry.
2. Although a wide range of narrow end taper dimensions are available, it should be noted that an infinite selection of tapers is not available (for assistance on the range of tapers available and length availability, please contact your nearest Service Centre).
3. Wide end dimensions of tapered LONGLINE 305® less than 305mm may be available subject to enquiry.

TAPER DIRECTION OF TAPERED LONGLINE 305®

All tapers are linear tapers. The tapers are manufactured in the standard mode (termed on the production line as FORWARD taper) or in the non-standard mode (termed on the production line as REVERSE taper).

The normal manufacture is "FORWARD" and unless specified the FORWARD taper will be produced.

The orientation of installation of the sheets will govern as to which end of the roof that laying can commence. On some projects the choice of laying direction is important and thus the selection of the correct direction of taper (Forward or Reverse) is vital.

Notes:

Although a wide range of Forward tapers are available, it should be noted that only a limited selection of Reverse tapers is available (for assistance on the range of Forward and Reverse tapers available, please contact your nearest Service Centre).

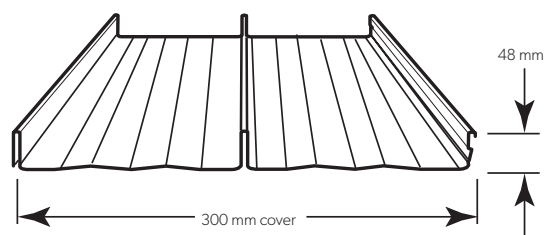

Fluted LONGLINE 305®

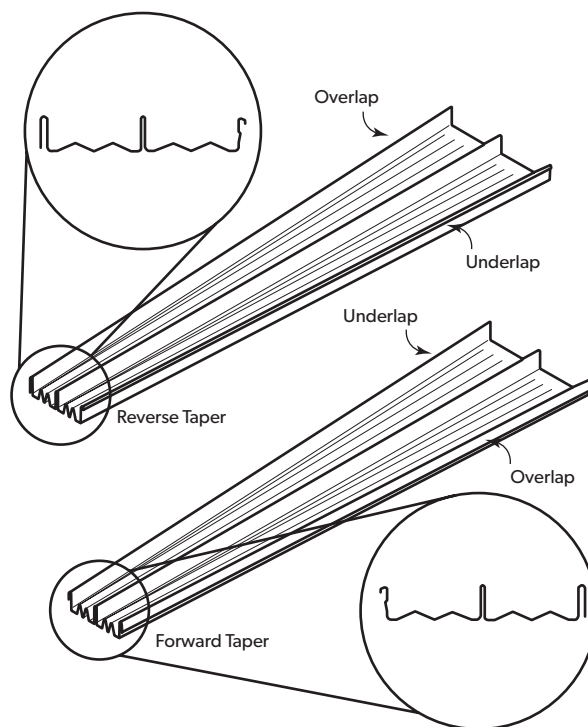

	Standard width (cover 305mm)
	Fluted (cover 300mm)
	Narrow end with dimension of approx. 265mm
	Narrow end with dimension of approx. 235mm
	Narrow end with dimension of approx. 155mm

PRODUCT DESCRIPTIONS

- All descriptions, specifications, illustrations, drawings, data, dimensions and weights contained in this catalogue, all technical literature and websites containing information from Lysaght are approximations only. They are intended by Lysaght to be a general description for information and identification purposes and do not create a sale by description. Lysaght reserves the right at any time to:

- (a) supply Goods with such minor modifications from its drawings and specifications as it sees fit; and
- (b) alter specifications shown in its promotional literature to reflect changes made after the date of such publication.

DISCLAIMER, WARRANTIES AND LIMITATION OF LIABILITY

- This publication is intended to be an aid for all trades and professionals involved with specifying and installing Lysaght products and not to be a substitute for professional judgement.
- Terms and conditions of sale available at local Lysaght sales offices.
- Except to the extent to which liability may not lawfully be excluded or limited, BlueScope Steel Limited will not be under or incur any liability to you for any direct or indirect loss or damage (including, without limitation, consequential loss or damage such as loss of profit or anticipated profit, loss of use, damage to goodwill and loss due to delay) however caused (including, without limitation, breach of contract, negligence and/or breach of statute), which you may suffer or incur in connection with this publication.
- Please note that all flat pan profiles can exhibit signs of oil canning under certain light conditions which can potentially be seen in the finish of the product. While this appearance can differ for all colours, it is typically more visible in darker colours. Oil canning is not a structural defect but simply an aesthetic issue. Designers should take this aspect into account upon selection and need to make a professional judgement on the profile suitability for the particular application. Please consult with Lysaght technical team for any additional advice.

© Copyright BlueScope Steel Limited 20 November, 2015

WWW.LYSAGHT.COM

Technical enquiries:
steeldirect@bluescopesteel.com or call 1800 641 417

LYSAGHT®, LONGLINE 305®, THERMATECH®, COLORBOND®, NOVALINE®, SHEERLINE® and ZINCALUME® are registered trademarks of BlueScope Steel Limited, ABN 16 000 011 058. The LYSAGHT® range of products is exclusively made by or for BlueScope Steel Limited trading as Lysaght.

