



The right way to attach almost anything to metal roofs!

## Installation Instructions

**S-5!® Warning!** Please use these products responsibly! Visit our website or contact your S-5! distributor for available load test results. The user and/or the installer of these parts is responsible for all necessary engineering and design for the intended use of these parts in an assembly or application. Visit [www.S-5.com](http://www.S-5.com) for more details.

### S-5! clamps for concealed fix application sold separately

#### Tools Needed

- Ratchet or Screw Gun
- 13 mm Socket
- Measuring Tape

#### Parts

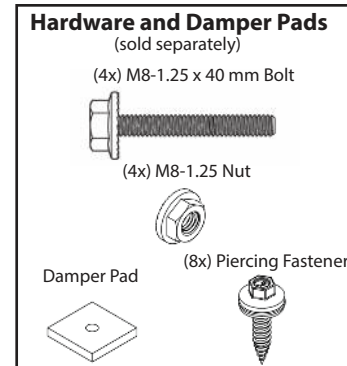
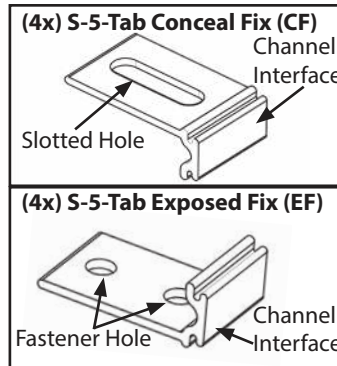
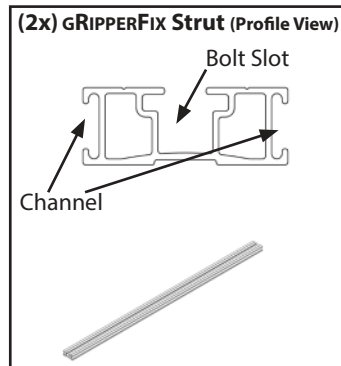

### To Install GRIPPERFIX on Concealed Fix

**1. Install the first two S-5! clamps:** install the first two clamps at the desired location to secure the downslope GRIPPERFIX Strut. (Please see installation instructions provided with clamps for specifics on clamp installation.)

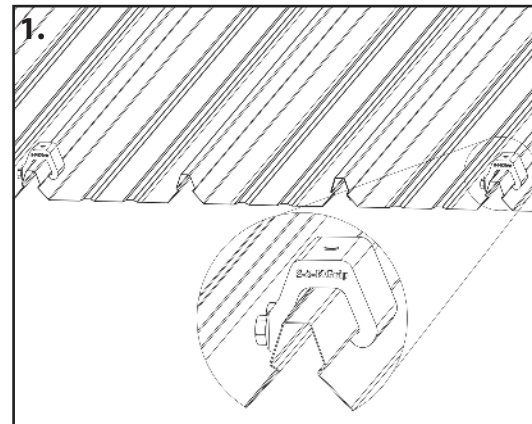

**2. Slide S-5-Tab Conceal Fix (CF) into channel of GRIPPERFIX Strut:** Slide two tabs into the channel as shown in (Fig 2a). Be sure that the surface with slotted hole is oriented upward. (Fig 2b).

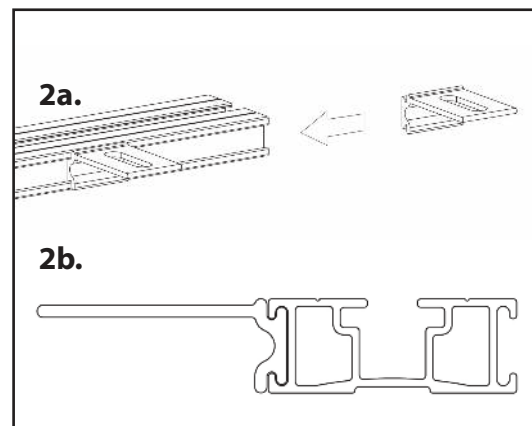

**3. Attach the gRIPPERFIX Strut to the clamps:** Slide the the Tabs into position over the clamps so the slotted holes align with the bolt holes in the clamps and the gRIPPERFIX Strut rests on the ribs or seams of the roof (**Fig. 3**). Using M8 x16 mm bolt (provided with clamp), secure the tabs to the clamps, anchoring the Strut into place.

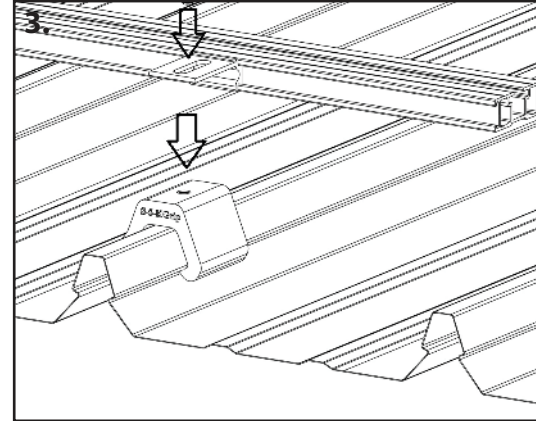

**4. Repeat the above procedure for the second Strut:** You may wish to leave the bolts finger tight, so final adjustments can be made as the condenser unit is mounted to the struts. (**Fig. 4**).

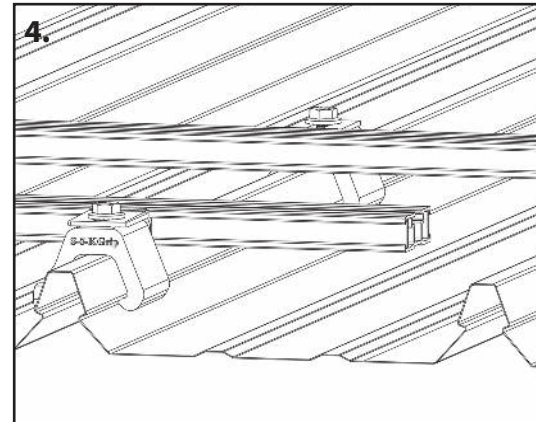

**5. Slide M8-1.25 x 40 mm Bolts into Bolt Slot and place Damper Pads:** Slide (2) M8-1.25 x 40 mm bolts into the top slot of each gRIPPERFIX Strut (**Fig. 5**). Position bolts such that they align with mounting holes of the condenser unit centered on the gRIPPERFIX Strut. Place Damper Pads over the shafts of the inserted bolts.

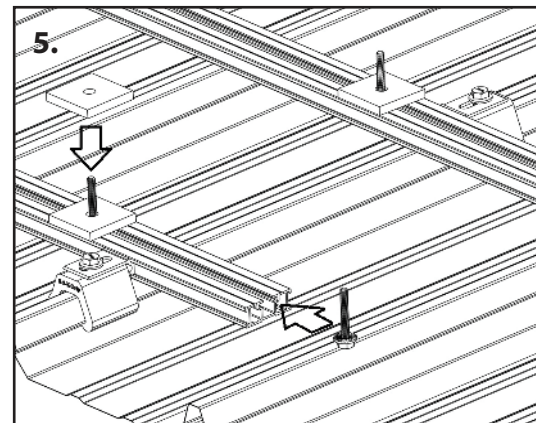

**6. Place condenser unit mounting holes over M8-1.25 x 40 mm Bolts atop Damper Pads and Fix to gRIPPERFIX Strut:** Some adjustment of the M8-1.25 x 40 mm Bolts & Damper Pads may be necessary to align with mounting holes of condenser unit. **Additional Damper Pads can be added to the downslope mounting locations to level the condenser unit if necessary.** Place the mounting holes on the feet of the condenser unit over the M8-1.25 x 40 mm bolts. Tighten the provided nuts onto the bolts. Check and tighten any remaining hardware. (**Fig. 6**) **Optional Step:** After the tabs have been bolted to the clamps, a pair of pliers can be used to crimp the channel on either side of each tab to prevent lateral migration.

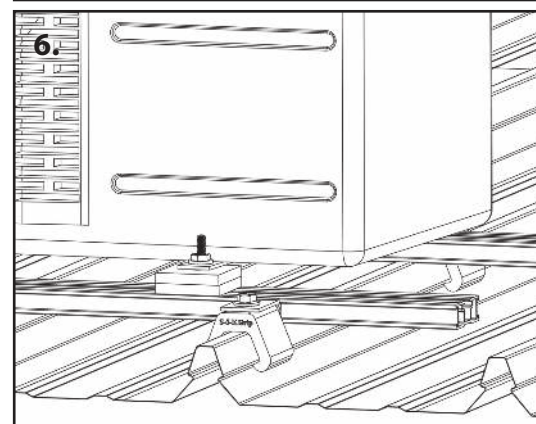

**S-5!® Warning! Please use this product responsibly!**

Products are protected by multiple U.S. and foreign patents. For published data regarding holding strength, fastener torque, patents, and trademarks, visit the S-5! website at [www.s-5.com](http://www.s-5.com). Copyright 2019, Metal Roof Innovations, Ltd. S-5! products are patent protected. S-5! aggressively protects its patents, trademarks, and copyrights.



The right way to attach almost anything to metal roofs!

## To Install GRIPPERFIX On Exposed Fix

**1. Slide S-5-Tab Exposed Fix (EF) into channel of GRIPPERFIX Strut:** Two S-5-Tab Exposed Fix (EF) should be used with each GRIPPERFIX Strut. Slide the tabs into the channel as shown in (Fig 1a) with EPDM strip facing toward bottom of rail (Fig 1b). These tabs will be the connection to the top of the roof profile ribs.

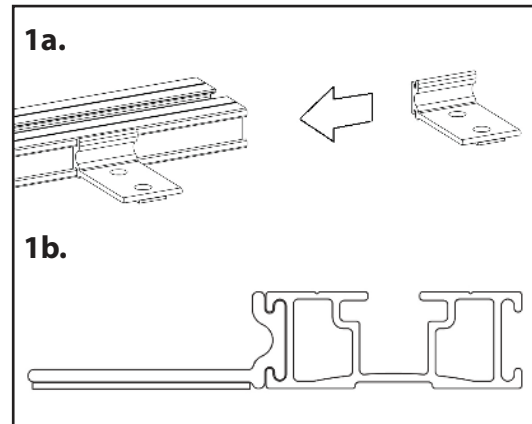

**2. Fasten the upslope GRIPPERFIX Strut to the roof ribs:** Align the S-5-Tab EF atop the ribs of the roof. The GRIPPERFIX Strut should rest on the ribs of the roof and be centered on attachment points left-to-right. Secure the S-5-Tabs directly into the top of the roof profile using the piercing fasteners provided. Drive the fastener until it is tight and the washer is firmly seated (Fig. 2). DO NOT over-drive fasteners; a slight extrusion of rubber around the washer is a good visual-tightness check.

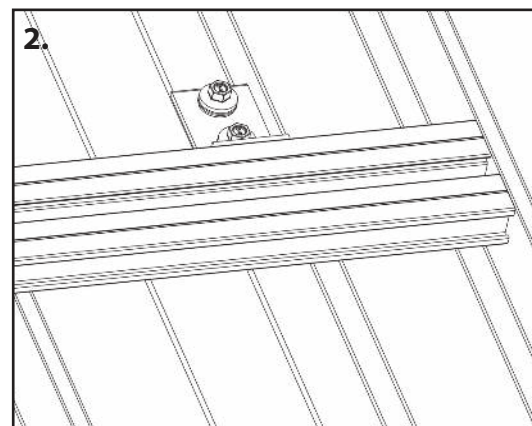

**3. Placing second Strut on roof (do not fasten down yet):** Following the previous steps, place the second Strut at the desired location, so that the bolt slots within the two GRIPPERFIX Struts are the same distance apart and consistent with the distance between mounting locations on the base of the condenser unit. (Fig. 3). DO NOT fasten to roof at this point.

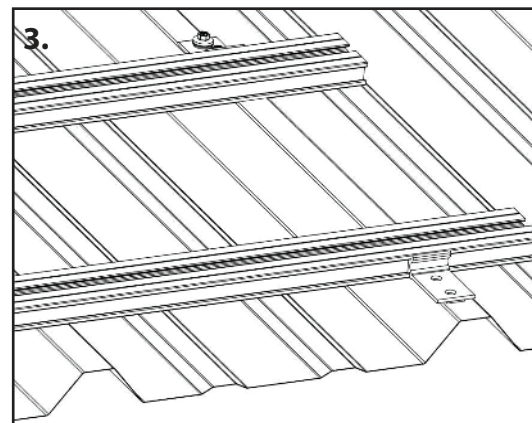

**4. Slide M8-1.25 x 40 mm Bolts into Bolt Slot and place Damper Pads:** Slide (2) M8-1.25 x 40 mm bolts into the top slot of each GRIPPERFIX Strut (Fig. 4). Position these bolts such that they align with mounting holes of the condenser unit centered on the GRIPPERFIX Strut. Place Damper Pads over the shafts of the inserted bolts.

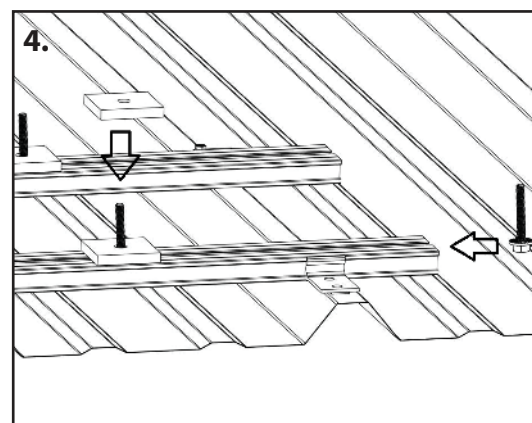

These instructions are for use by those experienced in the trade. Always follow appropriate safety precautions and use appropriate tools.

**5. Place condenser unit mounting holes over M8-1.25 x 40 mm Bolts atop Damper Pads and Fix to gRIPPERFIX Rail:** Some adjustment of the M8 Bolts & Damper Pads may be necessary to align with mounting holes of condenser unit. **Additional Damper Pads can be added to the downslope mounting locations to level the condenser unit if necessary.** Place the mounting holes on the feet of the condenser unit over the M8 bolts. Secure the installation by finger tightening the supplied nuts onto the bolts. **(Fig. 5).**

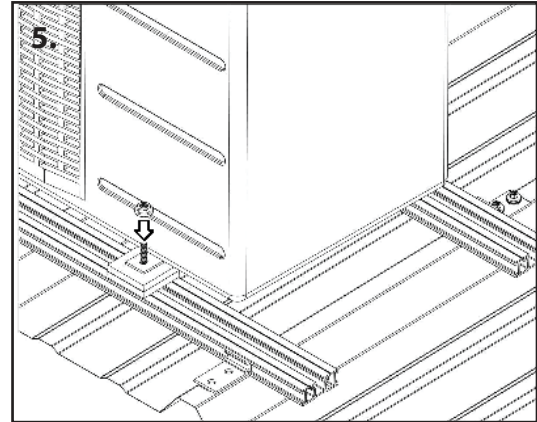

**6. Fasten the second gRIPPERFIX Rail to the roof ribs:** Secure the rail using furnished piercing screws as in Step 2. **(Fig. 6).** Make any necessary final adjustments and final tightening of all remaining hardware.

**Optional Step:** After the tabs have been screwed to the ribs, a pair of pliers can be used to crimp the channel on either side of each tab to prevent lateral migration.

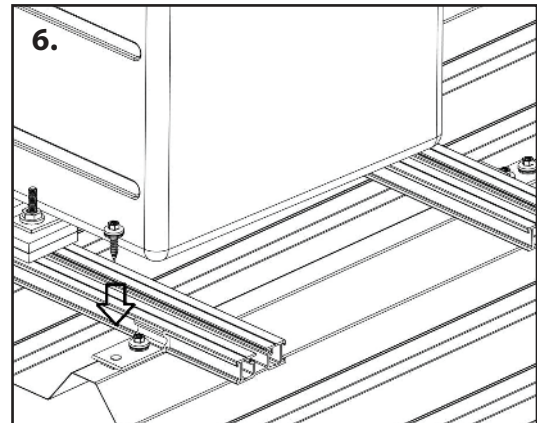

**S-5!® Warning! Please use this product responsibly!**

Products are protected by multiple U.S. and foreign patents. For published data regarding holding strength, fastener torque, patents, and trademarks, visit the S-5! website at [www.s-5.com](http://www.s-5.com).  
Copyright 2019, Metal Roof Innovations, Ltd. S-5! products are patent protected. S-5! aggressively protects its patents, trademarks, and copyrights.  
gRF-V1.3\_080619